

# Stereoselection at the Steady State by Stereoconvergent Reaction Topography

Nicholas C. DeMello and Dennis P. Curran\*

Contribution from the Department of Chemistry, University of Pittsburgh, Pittsburgh, Pennsylvania 15260

Received July 17, 1997

**Abstract:** A novel strategy for achieving stereoselection by engineering reactions to occur through a unique kinetic scheme is introduced. The strategy, named “complex stereoselection”, effects stereoselection as a result of intermediates at the steady state partitioning successively between competing chemical transformations. A mathematical description of the ratio of products produced in the kinetic strategy is derived, and computer simulation of that model demonstrates two principal advantages of this method: higher selectivity and more efficient conversion of substrates. These computer simulations were subsequently used to determine conditions for maximum stereoselection in these reactions via the framework of a series of hypothetical scenarios in six different incarnations of complex stereoselection. The resulting predictions present challenges to the field of experimental stereochemistry.

## Introduction

Stereoselectivity is a property unique to chemical processes that have the potential to either consume or produce a mixture of stereoisomers.<sup>1–3</sup> Advances in the design of stereoselective reactions have concentrated on developing and refining stereoselective recognition.<sup>4</sup> This involves maximizing the difference in the activation energy of competing reaction paths leading to (or from) stereoisomeric components of a reaction. Less often considered is the topography, or shape, of the reaction coordinate surface—the branching and merging of paths in the kinetic scheme of the reaction mechanism.

In this paper, we describe the conceptual and mathematical framework of a new strategy for stereoselection based on the orchestration of reaction topography. This strategy, which we call “complex stereoselection”, is fundamentally different from existing strategies. The selectivity in a complex process is not caused by either a simple stereoselective competition or the cumulative effect of many stereoselective competitions, but by reaction topography. Complex stereoselective topographies offer the unique and synthetically advantageous potential of providing a yield of a major product that exceeds the level of selectivity in any stereoselective event that may occur in the kinetic scheme. *In theory, a reaction with no stereoselective step can provide an effectively quantitative yield of a single product in a kinetically controlled process.* A complex stereoselective process occurs at the steady state and operates by the chemical equivalent of a physical resolution of stereoisomers.

(1) Eliel, E. L.; Wilen, S. *Stereochemistry of Organic Compounds*; Wiley-Interscience: New York, 1994; p 1208.

(2) Mislow, K. *Introduction to Stereochemistry*; W. A. Benjamin, Inc.: New York, 1966.

(3) (a) Helmchen, G. In *Houben-Weyl Methods of Organic Chemistry Pt A: General Aspects*; Vol. E 21a, Stereoselective Synthesis; Helmchen, G., Ed.; Georg Thieme Verlag: Stuttgart, Germany, 1995; pp 1–140.

(4) Treatises and books: (a) Izumi, Y.; Tai, A. *Stereo-Differentiating Reactions*; Academic Press: Japan, 1977; p 82. (b) Nógrádi, M. *Stereoselective Synthesis*; VCH: New York, 1996. (c) *Houben-Weyl Methods of Organic Chemistry*; Vol. E 21a, Stereoselective Synthesis; Helmchen, G., Ed.; Georg Thieme Verlag: Stuttgart, Germany, 1995. (d) Seyden-Penne, J. *Chiral Auxiliaries and Ligands in Asymmetric Synthesis*; Wiley: New York, 1995.

In this paper, we describe kinetic models for an assortment of variants of inter- and intramolecular reactions, both enantio- and diastereoselective. The accompanying paper provides experimental verification of the kinetic model of one of these processes.<sup>5</sup>

**Existing Modes for Stereoselection and Definition of Terms.** In organic reactions, stereoselection is typically quantified by providing enantiomeric (ee) or diastereomeric excesses (de). In this paper, we used the generalized quantity “stereomeric excess (se).” This is defined in the usual way, as shown in eq 1. A second measure of the effectiveness of stereoselectivity in a process is how much of the potential starting material is successfully converted to the excess major stereoisomer, which we will describe as the *excess yield* (eY). The excess yield is the difference between quantities of the major and minor isomer at a given time, divided by the total amount of starting material [SM]<sub>0</sub> that could potentially be converted to these isomers (eq 2).

$$\text{stereomeric excess}_t = \frac{[\text{major}]_t - [\text{minor}]_t}{[\text{major}]_t + [\text{minor}]_t} \quad (1)$$

$$\text{excess yield}_t = \frac{[\text{major}]_t - [\text{minor}]_t}{[\text{SM}]_0} \quad (2)$$

Together with the chemical yield (Y) of a stereoselective reaction, the stereomeric excess (se) and excess yield (eY) provide a triad of measures that describe efficiency. Respectively, they describe how efficiently the process converts material to product, how stereomerically pure the component isomers are, and how efficiently the process produces stereomerically pure material. The quantities are directly related; given any two values, the third can be calculated.

It is generally accepted that there are only two “elementary” modes of stereoselection, and that these require a competition

(5) (a) See: Curran, D. P.; Lin, C. H.; Qi, H.; Junggebauer, J. *J. Am. Chem. Soc.* 1998, 120, 342. See also: (b) Curran, D. P.; Qi, H. Y.; DeMello, N. C.; Lin, C. H. *J. Am. Chem. Soc.* 1994, 116, 8430. (c) Curran, D. P.; Qi, H. Y. *Helv. Chim. Acta* 1996, 79, 21.

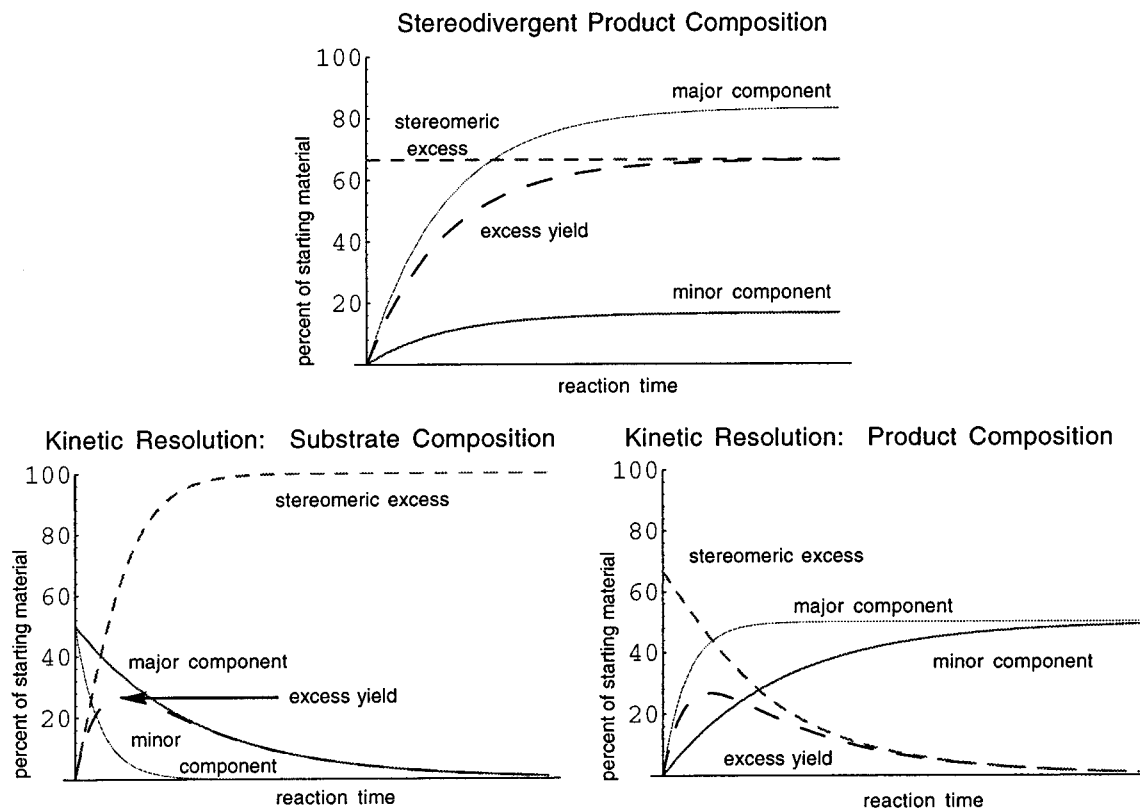

**Figure 1.** Component profiles of elementary stereoselective processes. Each graph is plotted with a selectivity ( $k_{\text{fast}}/k_{\text{slow}}$ ) of  $S = 5$  ( $\Delta\Delta G^\ddagger = 0.95$  kcal/mol at 25 °C).

between diastereomeric transition states.<sup>1-4</sup> The first is the mode where stereoisomeric substrates are transformed to the same or different products at different rates. This is often called “kinetic resolution”. Kinetic resolution is effectively a separation process that discriminates between two initial stereoisomers causing the compositions of initial stereoisomers in the product and the starting material to change simultaneously in an inverse fashion. The kinetic description of a first-order stereospecific system has been derived.<sup>6</sup>

Nógrádi describes the second elementary mode as “the case when out of two or more possible stereoisomeric products, arising from a single substrate, one is formed preferentially.”<sup>4b</sup> This mode of reaction is very common, though an accepted name has been the subject of vigorous discussion. We will call this *selective stereodivergence*. Stereoconvergence has been defined to describe a synthesis where “stereoisomerically differing starting materials yield identical products.”<sup>4b</sup> By implication, the reverse process, where a single starting material produces stereoisomerically differing products, can be described as stereodivergent and the moment of partitioning as a stereodivergent event. Selective stereodivergent reactions are not separation processes; they work instead by selective creation of one isomer instead of another.

According to Eliel,<sup>1</sup> stereodivergence occurs by one of two fundamentally distinct classes of transformation: stereoheterotopic facial addition and stereoheterotopic ligand substitution. Such processes are usually called “face selective reactions” and “group selective reactions” when a nonstatistical selectivity is observed. Transition states for stereotopically divergent reactions must be diastereomeric, but the overall process can be diastereo- or enantioselective, depending on the reaction part-

ners. The kinetics of selective stereodivergent systems are those of parallel reactions with different products.

The fundamental distinctions between the two different modes of elementary stereoselection are illustrated in Figure 1, which shows yield, se, and eY for hypothetical processes with selectivities of 5 as a function of time. The stereomeric excess (short-dashed lines) of the product of a selectively stereodivergent process (for example, enantioselective reduction of a ketone) is invariant over time, while in a kinetic resolution (for example, enzymatic acylation of a racemic mixture of alcohols) the se of the substrate increases with time as the se of the product decreases. While the stereomeric excess (short-dashed lines) of the substrate increases to effectively 100%, it does so at the expense of the yield of the desired isomer, which tapers off to zero as the se of the sample increases. For the same degree of selectivity, selective stereodivergence results in a greater excess yield of the desired isomer, while erosion of a material by kinetic resolution offers a greater purity of the sample (stereomeric excess).

The isomer composition due to one stereoselective event can be enhanced or eroded by concurrent or subsequent stereoselective events in the reaction scheme. We will call reactions composed of multiple stereoselective events operating in concert “composite stereoselective processes”. Reactions of meso substrates often occur by a powerful type of composite process.<sup>7</sup> A typical example is Sih’s enzymatic hydrolysis of a diester.<sup>8</sup> This involves two cooperative stereoselective processes, as shown in Figure 2. Conversion of the diester to the monoester is a group-selective stereodivergent event that forms one enantiomer preferentially. The ratio of the two enantiomeric monoesters is further enhanced by a kinetic resolution—a second

(7) Ward, R. S. *Tetrahedron-Asymmetry* **1995**, *6*, 1475.

(8) Wang, Y.-F.; Chen, C.-S.; Girdaukas, G.; Sih, C. J. *J. Am. Chem. Soc.* **1984**, *106*, 3695–3696.

(6) Capellos, C.; Bielski, B. J. H. *Kinetic Systems: Mathematical Descriptions of Chemical Kinetics in Solution*; Wiley: New York, 1972.

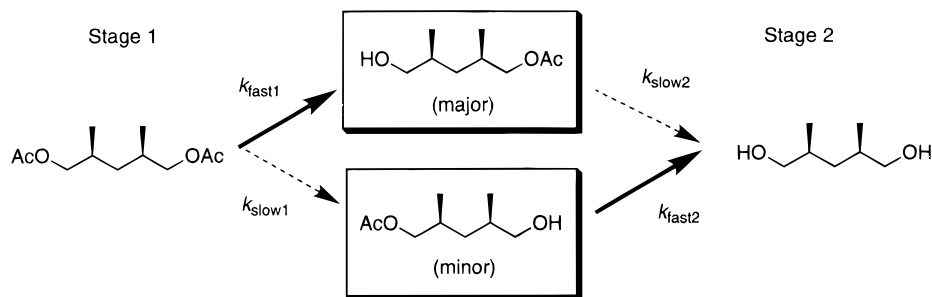

Figure 2. Composite stereoselective processes can enhance stereoisomeric purity.

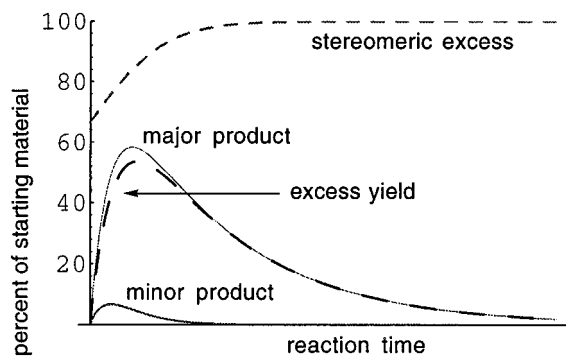

Figure 3. Hypothetical component profile of stereoisomers in Figure 5.

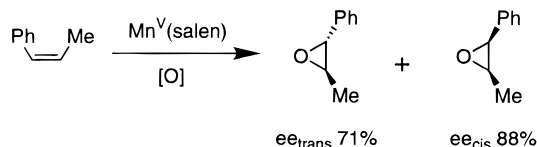

Figure 4. Different ee in the same reaction.

stereoselective event—in which the minor isomer is consumed more quickly than the major one. These types of reactions can provide products with very high levels of stereomeric excess.<sup>9</sup>

Figure 3 provides a hypothetical example of the product distribution in this type of process calculated from the relevant time-dependent equations. Considering the case where  $k_{fast1} = k_{fast2}$  and  $k_{slow1} = k_{slow2}$ , we plotted the stereoisomeric profile of the intermediates over time with a selectivity of 5 for both  $k_{fast1}/k_{slow1}$  and  $k_{fast2}/k_{slow2}$ . Acting in concert, the two selections result in greater stereomeric excess (short-dashed line) than either selective event alone can account for (compare with Figure 1). But there is a price; a decrease in the excess yield of the desired isomer (long-dashed line) relative to the yield predicted by a single selection (with the same stereoselective recognition of 5) occurs over time.

Another type of composite process involves only combinations of selective stereodivergence (or convergence) and has no kinetic resolution component. For example, while examining the epoxidation of cis olefins with a chiral salen-ligated Mn catalyst, Jacobsen observed that epoxidation can result in cis and trans epoxides from the same substrate in the same reaction with different enantiomeric purities (Figure 4).<sup>10</sup>

Jacobsen explained the different enantiomeric purities of the epoxides by suggesting that the epoxidation occurred in a stepwise fashion (Figure 5). The initial stereodivergent event—formation of the first carbon oxygen bond—occurs with

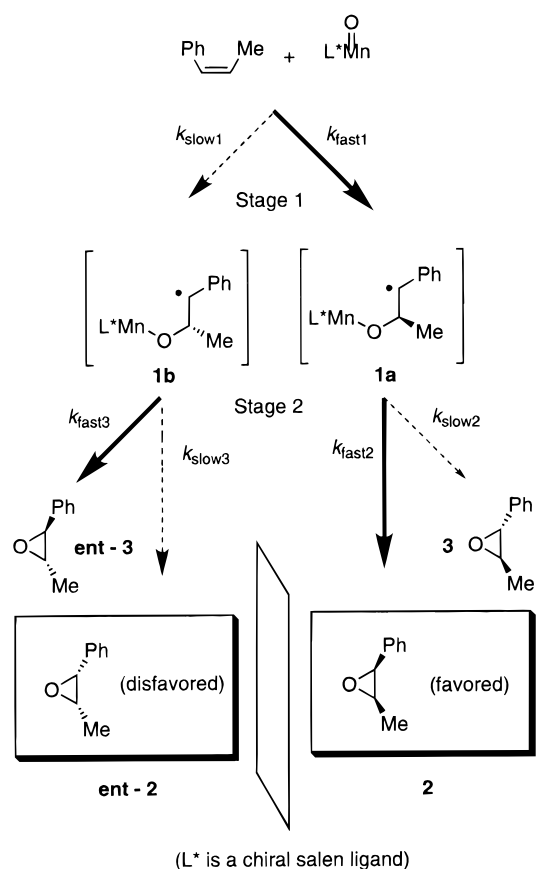

Figure 5. Composite selection by consecutive stereodivergent processes. ( $L^*$  is a chiral salen ligand)

facial selectivity. Subsequently, each of the diastereomeric intermediate products **1a,b** encounters a separate stereodivergent event.<sup>11,12</sup> The event that precedes formation of the major product favors generation of the cis isomer **2** relative to the trans side product **3**, while the event that precedes formation of the minor product partitions more of the intermediate to the trans side product **ent-3** than the cis isomer **ent-2** (Figure 5). This model of consecutive selective events was supported by Jacobsen's analysis of the mathematical description of the rates and product distributions.

(11) More generally, the intermediates are diastereomeric, so the event does not have to be stereodivergent, it simply has to be divergent. Processes such as this can in principle deplete the minor stereoisomer by providing lower energy pathways to regioisomers or even completely different products.

(12) (a) Bolm, C.; Suhlingloff, G. *J. Chem. Soc., Chem. Commun.* **1995**, 1247. (b) Kagan, H. B. *Croat. Chim. Acta* **1996**, 69, 669. (c) Ward, D. E.; How, D.; Liu, Y. *J. Am. Chem. Soc.* **1997**, 119, 1884. (d) Mikami, K.; Matsukawa, S.; Nagashima, M.; Funabashi, H.; Morishima, H. *Tetrahedron Lett.* **1997**, 38, 579. (e) Davis, A. P. *Angew. Chem., Int. Ed. Engl.* **1997**, 36, 591. (f) Vedejs, E.; Chen, X. *J. Am. Chem. Soc.* **1997**, 119, 22584.

(9) Schreiber, S. L.; Schreiber, T. S.; Smith, D. B. *J. Am. Chem. Soc.* **1987**, 109, 1525.

(10) Zhang, W.; Lee, N. H.; Jacobsen, E. N. *J. Am. Chem. Soc.* **1994**, 116, 425–426.

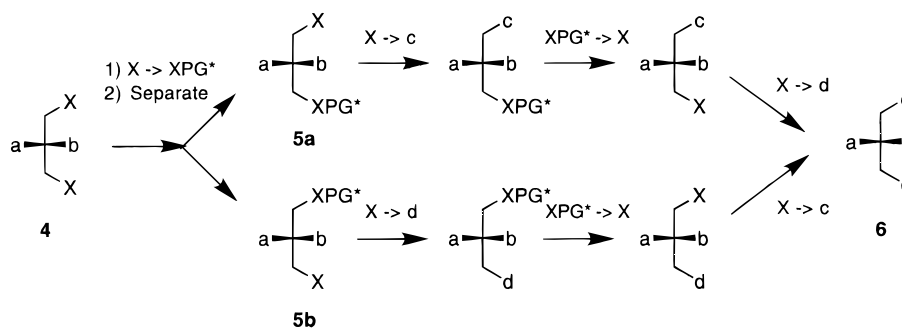

**Figure 6.** The stereoconvergent strategy.

The second composite stereoselective process is fundamentally different from the first. Jacobsen's enhancement occurs in a stepwise, serial fashion while Sih's system effects a simultaneous, parallel enhancement. In the Sih system, a common stereomeric mixture is manipulated by two simultaneous cooperative processes, while in Jacobsen's system, initial stereofacial selective generation of diastereomeric reactive intermediates is followed by elaboration of those intermediates to a final product through subsequent stereofacially selective additions. Since there is no kinetic resolution, the ratio of product stereoisomers is not time dependent.

A number of other reaction topographies share some of the features of the strategies in Figures 2 and 5 as well as adding unique features of their own.<sup>12</sup> Clearly, composite stereoselection—the linking of multiple, discreet stereoselective events—provides a powerful suite of strategies for enhancing isomeric purity. However, all methods of composite stereoselection suffer from a shared shortcoming: “enhancement” of an initial stereoselective event comes at the cost of reduced yield in the desired isomer. In Sih's system, both desired and undesired isomers are lost to the selective erosion of the stereomeric mixture, while in Jacobsen's system the reactive intermediates on a path to the final products are selectively detoured to a side product. Even if the stereomeric recognition is ideal in enhancing selection in stage 2 of each system, it is only possible to equal, never exceed, the excess yield of stage 1. Said another way, the final yield of the major stereoisomer can never exceed the level of selectivity in the first stereodivergent event. So it is not appropriate to say that any of these methods “enhance” the selectivity of an initial stereodivergent event. Instead, these methods enhance the se of a final product relative to an intermediate mixture by stereoselective erosion of that mixture.

Jacobsen's reaction (Figure 5) is a two-step face-selective process that works through the agency of transient stereomeric intermediates **1a,b** that are probably present in low concentrations and at a steady state. In a standard two-step process that produces stable rather than transient intermediates, the divergent selectivity in the second stage is not necessary because the diastereomeric intermediates could be separated by chromatography, crystallization, distillation, or another physical process and then converted to the final products. The excess yield is again limited by the selectivity in the first stage, and the stereomeric excess of the final product is limited only by the efficiency of the physical separation process. We like to view Jacobsen's process as one in which a kinetic separation (the second stage of the reaction) replaces a physical separation. One advantage of the kinetic separation at the steady state over physical separation is clear from Jacobsen's experiments: the process can be catalytic in one of the components. Two other crucial advantages become apparent on some reflection: (1) if

one of the competing processes in stage 2 is bimolecular, then there is a simple experimental variable (concentration) that can be used to alter stereoselection, and (2) only one of the two competing processes in stage 2 needs to be selective.

## Results and Discussion

The new “complex” stereoselective processes in this paper derive from analogy between physical resolution and kinetic resolution. The physical resolution is the process of “stereoconvergent synthesis”, proposed by Fischli in 1975.<sup>13</sup> A stereoconvergent synthesis involves an initial separation of the stereoisomers from a poorly stereoselective or nonselective stereodivergent reaction, and subsequent complementary conversion of both products to a single stereoisomer. Specifically, Fischli proposed the nonselective monoprotection of two enantiotopic reactive groups of **4** with a chiral agent (XPG\*), then physical separation of the resulting diastereomers **5a,b** (Figure 6). By first reacting the unprotected group of one isomer, deprotecting the other group, then treating that newly unprotected group with a different reaction than the first, and then applying the same steps *in reverse order* to the second isomer, either of two stereoisomers could be generated with 100% stereomeric excess—theoretically no material must be sacrificed to achieve this high purity (Figure 6). Convergence based on face selection can also be accomplished.<sup>14</sup>

If Fischli's separation could be effected chemically rather than physically, it would be possible (in principle) to diverge from a single starting material and reconverge simultaneously to a single product—potentially with only catalytic amounts of reagents. Like the process in Figure 6, selection in the divergent event would not be required for the overall process to be stereoselective.<sup>15</sup> The extrapolation of this analogy leads to the identification of a new mode of stereoselection. This mode will distinguish itself from other classes of elementary and composite modes of stereoselection by containing no instances of selective competition between diastereomeric transition states, by allowing the eY of the reaction to exceed the selectivity of the sole stereodivergent event, and by having both the se and the eY dependent on the concentration of a reaction component other than the substrate. In short, the yield of the product from one path is compounded by formation of the same product from another path.

(13) Fischli, A.; Klaus, M.; Mayer, H.; Schönholzer, P.; Rüeegg, R. *Helv. Chim. Acta* **1975**, *58*, 564–584.

(14) Cohen, N.; Lopresti, R. J.; Neukom, C.; Saucy, G. *J. Org. Chem.* **1980**, *45*, 5.

(15) Elegant stereoconvergent strategies that rely on diastereomer formation with chemical, not physical separation have been introduced for resolutions of racemic mixtures. These all rely on selections at the first stage of the process. In general, a pair of enantiomers is selectively converted into two different diastereomers that are then processed with parallel reactions to the same product. See: Harada, T.; Shintani, T.; Oku, A. *J. Am. Chem. Soc.* **1995**, *117*, 144. Davis, A. P. *Angew. Chem., Int. Ed. Engl.* **1997**, *36*, 591.

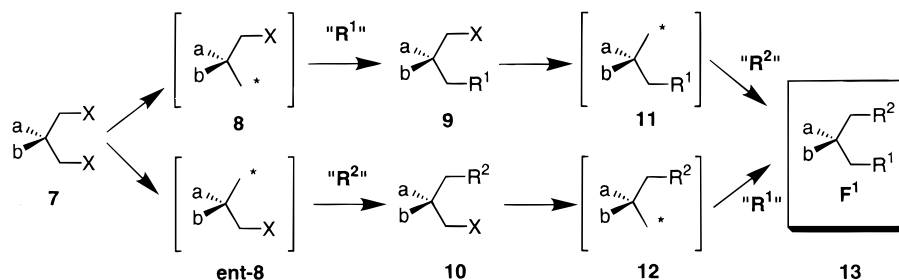

Figure 7. Selection by chemical stereoconvergence.

We fashioned a single reaction whose kinetic topography contained a stereoconvergent process analogous to the strategy Fischli based on physical separation. Specifically, we hypothesized a reaction where stereotopic groups are activated without selection and functionalized by two competing processes (" $R^1$ " and " $R^2$ " in Figure 7) in such a way that the order of the steps of the reaction mirrors the order of reactions of a stereoconvergent synthesis—the stereomeric intermediates **8** and **ent-8** are functionalized in opposite order by the two processes. The nature of the activation is not important in a simple analysis, so we simply use the symbol "\*" to represent a hypothetical functional group or reactive intermediate that is different from its predecessor *X* and that reacts with  $R^1$  and  $R^2$ . In contrast, *X* does not react with  $R^1$  or  $R^2$ .

In the idealized enantioselective process in Figure 7, the yield, excess yield, and stereoisomeric excess of **13** are all 100%. The first step (activation of **7** to give **8** and **ent-8**) is an elementary stereotopic ligand substitution, but the group selectivity in this step—dramatic, slight, or nonexistent—has no effect on the stereomeric nature of the final product because of the convergence of both initial stereomeric reactive intermediates to a single stereoisomer. The idealized process is thus a group selective reaction in which the level of group selectivity in the final product is independent of the group selective step. We will show below that in actual reaction topographies, the group selective step may or may not influence the overall selectivity; however, even when it does, its effect may be enhanced or overridden by the subsequent stereoconvergent process.

Stereoconvergence can be made to occur at the steady state if two conditions exist. First, at least one of the competing processes (reactions with " $R^1$ ", for example) must be stereoselective. Second, the other processes (reactions with " $R^2$ ", for example) must have rates of reaction that are in competition with the two rates of the first process. Ideally, the rate of the reactions with  $R^2$  is between the other two:  $\nu_{R^1 \text{ fast}} > \nu_{R^2} > \nu_{R^1 \text{ slow}}$ .<sup>16</sup> Consider an enantioselective process in which the reagent  $R^1$  is chiral and transforms the intermediates **8** and **12** (which have the same configuration) into products at rates very much faster than the related intermediates **ent-8** and **11**. This process provides enantiomer **13** regardless of the partitioning in the initial group selective step. If **8** is initially formed from **7**, its reaction with  $R^1$  is a fast one ( $\nu_{R^1 \text{ fast}} > \nu_{R^2}$ ), and **9** is produced. Now activation provides the enantiomer **11** mismatched with  $R^1$  ( $\nu_{R^1 \text{ slow}} < \nu_{R^2}$ ) and so reaction occurs with  $R^2$  to give **13**. Initial activation on the other enantiotopic group provides the enantiomer **ent-8**, which reacts with  $R^2$  because it is mismatched with  $R^1$ . The second activation provides the matched enantiomer **12**, which rapidly reacts with  $R^1$  to again provide **13**. The whole process can be made catalytic (on paper) by attaching

$R^1$  to a chiral catalyst and establishing a standard catalytic cycle.

Operating at the steady state is crucial for the success of the hypothetical process. At the steady state, the rates of reactions producing and consuming transient intermediates (in brackets) are assumed to be equal, and the concentration of these intermediates is low and stationary. This allows for an ordered timing of the parallel processes. Each time a compound **7** is activated, it always reacts with  $R^1$  or  $R^2$  prior to the second activation. If the reactions forming **8** and **ent-8** were much faster than those consuming them, then **8** and **ent-8** would both quickly be processed to a doubly activated intermediate. A standard group selective reaction of this intermediate would then occur. This process is conceptually the same as if *X* were never there, and the achiral reagent  $R^2$  has no effect on the selectivity. The steady state also establishes a constant concentration gradient between **8** and **ent-8** from which the stereoselection derives. In the (unrealistically simple) model in Figure 7, the concentration of the slower reacting enantiomer **ent-8** with respect to  $R^1$  will be infinitely higher than that of the fast reacting enantiomer **8**. One then simply needs a component  $R^2$  that reacts with **ent-8** at a suitable rate to maintain the steady state but not so fast that it reacts with **8** in competition with  $R^1$ . The same holds (in reverse) for reactions of **11** and **12**. The process capitalizes on the natural concentration gradients set up at the steady state by the different rates of reaction of intermediates with  $R^1$ .

The process is clearly related to a kinetic resolution; enantiomeric intermediates **8** and **ent-8** react with a chiral reagent  $R^1$  at different rates. However, unlike a kinetic resolution, the products of this reaction (**9** and **10**) are not stereoisomers; indeed they are not isomers at all. Rather, selection is a function of a two-stage partitioning of the starting material by chemoselective competition. Also unlike a kinetic resolution, the ratio of final stereoisomeric products is not time (or conversion) dependent but constant (assuming that reactions are pseudo first order). Even though it is not chiral, the reagent  $R^2$  is essential for the process and its rate of reaction with intermediates is crucial. The need for this reagent and the dependence of the final isomer ratio on its rates of reaction (and hence concentration) are also unique features of this complex process; no elementary or composite stereoselection process exhibits these features. In short, though the complex process contains the elementary processes of group selection and kinetic resolution, it is not a composite of these processes. The selectivity is a direct result of the stereoconvergent reaction topography.

The analysis in Figure 7 is simplified by the assumption that the rates of all possible competing reactions of each intermediate are negligible. This will never be the case in practice. Inclusion of all the competing processes by allowing every intermediate to react competitively with  $R^1$  and  $R^2$  results in a complex reaction topography that is shown in Figure 8 with free radicals in place of the generic intermediates. In this figure, bold and dotted arrows are used to represent respectively fast and slow

(16) The second transformation may also be selective. If so, the four rates of reaction must be such that one stereoisomeric intermediate prefers one transformation, and the other radical shows a preference for the second transformation.

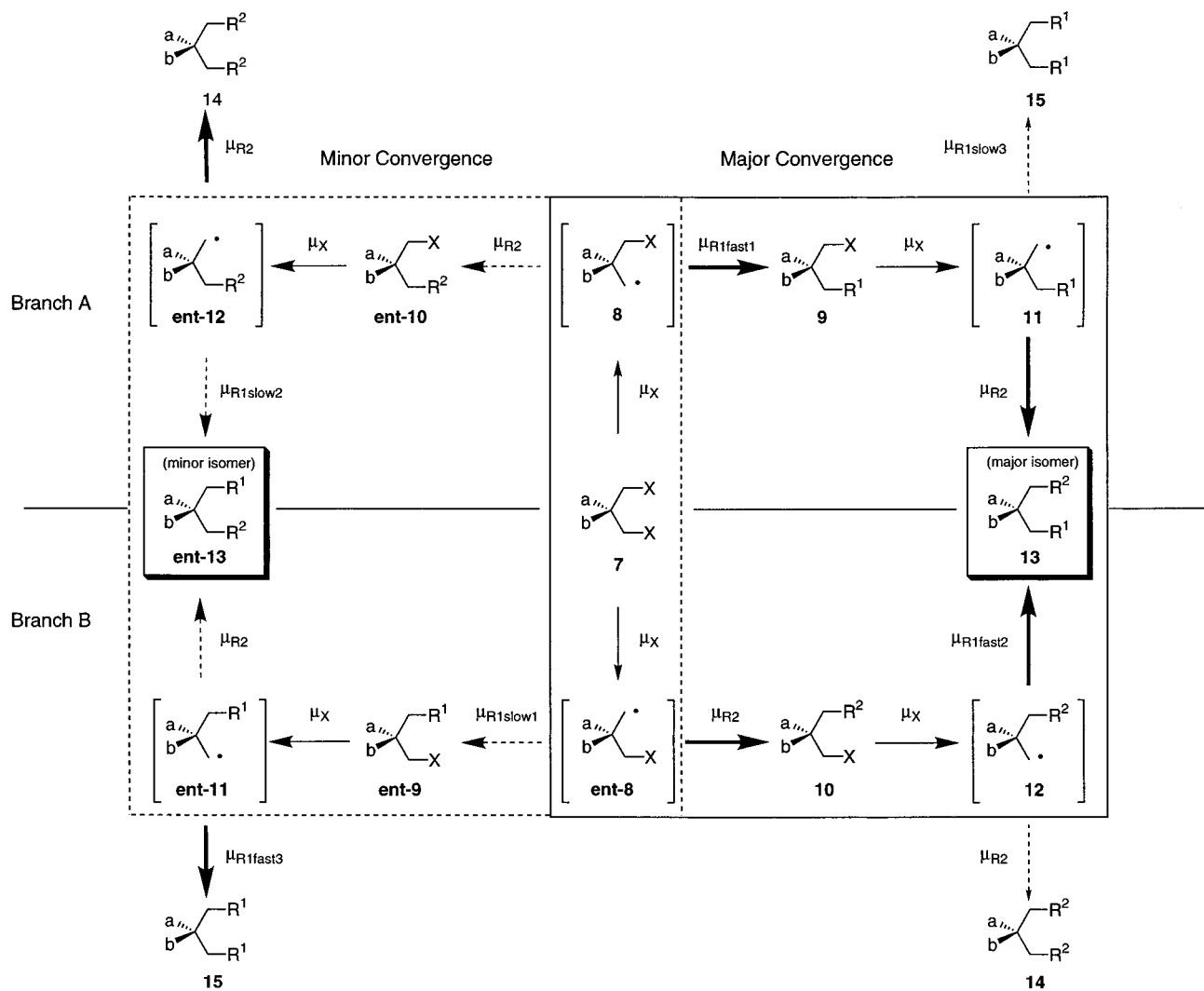

**Figure 8.** The generalized stereoconvergent reaction topography.

stereoselective reactions. Standard arrows represent nonselective reactions. The primary (that is, most rapid) reaction paths are stereoconvergent to the same isomer, so this is the “major convergence.” The major convergence is in the solid box in Figure 8, which is identical with Figure 7. Because the order of the two transformations (“R<sup>1</sup>” and “R<sup>2</sup>” in this example) can be varied, the potential for a second, disfavored stereoconvergent process—the minor convergence—also exists. The minor convergence is shown in the dotted box. Finally, any path can ultimately yield an achiral product (**14** or **15**) resulting from leakage outside of one convergence or the other by reaction with the same reagent twice.<sup>17</sup>

The first step, abstraction of X to make **8** and **ent-8**, is an elementary group selective process, and it divides the reaction into branches A and B. However, these intermediates are not irreversibly committed to any product and can still enter either the major or minor convergence. The first stage of selection occurs when the initial isomers **8** and **ent-8** partition chemoselectively into one of the two convergent systems. Partitionings of both isomers **8** and **ent-8** favor the same convergent system (the solid-boxed portion of Figure 8), collecting the majority of starting material (regardless of how it initially partitions into

**8** and **ent-8**) into the reaction paths leading to the major isomer **13**. This selective stereoconvergence is responsible for the ability of the system to generate excess yields greater than the excess yield of the first stereodivergent event, and is the same as that shown in Figure 7.

The convergent selection is enhanced further by successive selections at the intermediate **11/ent-11** and **12/ent-12** isomers. These intermediates appear at opposing corners of Figure 8. The majority of material from **8** in the major convergence is allowed to progress to the major isomer **13** unimpaird, while the majority of the material from **ent-8** that finds itself in the minor convergent system is eroded to the side product **15**. A similar enhancement of material in the major convergence and erosion of material in the minor convergence occurs in branch B.

Each pair in a succession of selections—first at the **8/ent-8** isomers and then at either the **11/ent-11** or **12/ent-12** isomers—is conceptually related to the consecutive composite selection of Jacobsen in Figure 5. However, unlike Jacobsen’s system, the selections in Figure 8 are not partitionings between stereoisomers. No stereoselection occurs to enhance the favoring of material in the major convergence or the disfavoring of material in the minor convergence. Instead of a competition between the same reaction in two different chiral environments, the chemoselectivity observed is the result of a competition between the rates of two different types of reaction. Therefore, the rates

(17) In fact, these achiral products are formed through convergences of their own, which are superimposed until the last step on the other convergences. In this respect, the “leakage” in Figure 8 is an artifact of representing the reaction topography in two dimensions.

of reaction can be varied independently and easily by changing either reagents or reaction concentrations.

In short, the advantages of this system are 2-fold. First, stereoconvergence allows the system to ignore the selection in the one step where stereomeric transition states compete (**7** → **8** or **ent-8**), and thus exceed the excess yield of that initial stereodivergent event. Second, successive resolution of the reactive intermediates by chemoselective events allows the system to generate high stereomeric excess—without stereoselective competition. Therefore, selectivity can be easily optimized by simply manipulating the rates of the two component transformations.

To better understand the consequences of stereoconvergent reaction topographies, we derived a mathematical expression for the product distributions of the stereoconvergent system as a function of the rates of reaction. First, we derived functions for the general stereoconvergent model with arbitrary reaction rates, and then customized these functions for six specific types of chemical reactions. Both the derivations and customizations are contained in the Supporting Information.

Equations 3–6 are the product distribution functions of the general stereoconvergent model as expressed in percent yield of products in Figure 8. The symbol  $\mu$  represents the rate of a given reaction divided by the concentration of the substrate associated with that rate. In a first-order reaction,  $\mu$  equals the rate constant, and in a second-order reaction,  $\mu$  equals the rate constant times the concentration of the reagent.  $P_A$  is a value between zero and one that describes the partitioning on **7** into branch A; it follows that partitioning into branch B =  $1 - P_A$ .

$$[14]_{\%} = P_A \frac{\mu_{R^1 \text{ slow}2}}{\mu_{R^1 \text{ slow}2} + \mu_{R^2}} \cdot \frac{\mu_{R^1 \text{ fast}1}}{\mu_{R^1 \text{ fast}1} + \mu_{R^2}} + (1 - P_A) \frac{\mu_{R^1 \text{ fast}2}}{\mu_{R^1 \text{ fast}2} + \mu_{R^2}} \cdot \frac{\mu_{R^1 \text{ slow}1}}{\mu_{R^1 \text{ slow}1} + \mu_{R^2}} \quad (3)$$

$$[15]_{\%} = P_A \frac{\mu_{R^2}}{\mu_{R^1 \text{ slow}2} + \mu_{R^2}} \cdot \frac{\mu_{R^1 \text{ fast}1}}{\mu_{R^1 \text{ fast}1} + \mu_{R^2}} + (1 - P_A) \frac{\mu_{R^1 \text{ fast}3}}{\mu_{R^1 \text{ fast}3} + \mu_{R^2}} \cdot \frac{\mu_{R^2}}{\mu_{R^1 \text{ slow}1} + \mu_{R^2}} \quad (4)$$

$$[11]_{\%} = P_A \frac{\mu_{R^2}}{\mu_{R^1 \text{ slow}3} + \mu_{R^2}} \cdot \frac{\mu_{R^1}}{\mu_{R^1 \text{ fast}1} + \mu_{R^2}} + (1 - P_A) \frac{\mu_{R^2}}{\mu_{R^1 \text{ fast}3} + \mu_{R^2}} \cdot \frac{\mu_{R^2}}{\mu_{R^1 \text{ slow}1} + \mu_{R^2}} \quad (5)$$

$$[\text{ent-11}]_{\%} = P_A \frac{\mu_{R^1 \text{ slow}3}}{\mu_{R^1 \text{ slow}3} + \mu_{R^2}} \cdot \frac{\mu_{R^2}}{\mu_{R^1 \text{ fast}1} + \mu_{R^2}} + (1 - P_A) \frac{\mu_{R^2}}{\mu_{R^1 \text{ fast}2} + \mu_{R^2}} \cdot \frac{\mu_{R^1 \text{ slow}1}}{\mu_{R^1 \text{ slow}1} + \mu_{R^2}} \quad (6)$$

To illustrate the customization and use of the equations to interpret experimental observations, we chose the hypothetical tin hydride reduction shown in Figure 9. The discussion here will focus on conceptual points, and we will use this reaction simply to show an example of a transformation and to use the kinetic models to calculate what the product yields and ratios would be given reasonable but arbitrary reaction rates. We stress that this example has not been studied by experiment, and that the calculated ratios are not predictions but simple “what if” illustrations. The analysis is pursued in more detail in the following paper, where a collection of related experi-

mental systems were investigated with the goal of providing experimental support for the model. In that paper, the model is used to calculate actual radical cyclization rate constants by fitting to experimental data.

The complete mechanism for reactions of **16** is shown in Figure 9 in a parallel fashion to the generalized process in Figure 8. The intermediates are radicals, and the two competing processes are cyclization and tin hydride reduction. Reduction of **16** can give exo (**17x**) or endo (**17n**) diastereoisomers or the doubly reduced isomer **18**. Throughout Figure 9, the letters “x” and “n” designate diastereoisomers which either are exo or endo or would be exo or endo if radical cyclization occurred. Further, the terms “exo” and “endo” in this paper refer to stereochemistry in bicyclic systems; from the regiochemical standpoint, all cyclizations are 5-*exo*. The radical precursor **16** is chiral and abstraction of the diastereotopic “X” groups provides diastereomeric radicals **19x** and **19n**. Because these are diastereomers, they (in principle) cyclize at different rates. Thus, no additional chiral reagent is needed in a diastereoselective complex process. It is not required that tin hydride react with any intermediate radicals at different rates. Indeed, to simplify the kinetic model we make the usual assumption that the rates of all intermediate radicals with tin hydride are the same; we also assume that these rates are first order (in other words, at fixed tin hydride concentrations).

Because intramolecular cyclization can occur only once for a given substrate, the side corresponding to “double cyclization” is not possible in this system. What this means is that all intermediates passing through branch A of the major convergence must end up at **17x** while all intermediates passing through branch B of the minor convergence must end up at **17n**. Substituting rate constants into the general model (eqs 4–7) and simplification results in specific product distribution models in eqs 7–9.

$$[17x]_{\%} = \frac{1}{2} \left\{ \frac{k_{\text{fast}1}}{k_{\text{fast}1} + k_{\text{H}}[\text{Sn}]} + \frac{k_{\text{fast}2}}{k_{\text{fast}2} + k_{\text{H}}[\text{Sn}]} \cdot \frac{k_{\text{H}}[\text{Sn}]}{k_{\text{slow}1} + k_{\text{H}}[\text{Sn}]} \right\} \quad (7)$$

$$[18]_{\%} = \frac{1}{2} \left\{ \frac{k_{\text{H}}[\text{Sn}]}{k_{\text{slow}2} + k_{\text{H}}[\text{Sn}]} \cdot \frac{k_{\text{H}}[\text{Sn}]}{k_{\text{fast}1} + k_{\text{H}}[\text{Sn}]} + \frac{k_{\text{H}}[\text{Sn}]}{k_{\text{fast}2} + k_{\text{H}}[\text{Sn}]} \cdot \frac{k_{\text{H}}[\text{Sn}]}{k_{\text{slow}1} + k_{\text{H}}[\text{Sn}]} \right\} \quad (8)$$

$$[17n]_{\%} = \frac{1}{2} \left\{ \frac{k_{\text{slow}2}}{k_{\text{slow}2} + k_{\text{H}}[\text{Sn}]} \cdot \frac{k_{\text{H}}[\text{Sn}]}{k_{\text{fast}1} + k_{\text{H}}[\text{Sn}]} + \frac{k_{\text{slow}1}}{k_{\text{slow}1} + k_{\text{H}}[\text{Sn}]} \right\} \quad (9)$$

The stereomeric excess and excess yield of the isomers **17x/17n** and yields of all products predicted by these equations were plotted over a range of  $k_{\text{H}}[\text{Sn}]$  from zero to 1.5 times  $k_{\text{fast}}$  (with  $k_{\text{slow}}$  of  $5 \times 10^5 \text{ s}^{-1}$  and a selectivity of 5 in favor of exo for cyclization of both intermediates **19** and **21**) and the resulting plots are shown in Figure 10a. For these plots, the initial stereodivergent event (group selective abstraction of X) was set to occur without selectivity ( $P_A = 1/2$ ).

These plots reveal some of the interesting features of the reaction. At low tin hydride concentration, both the fast and slow cyclization are faster than hydrogen transfer. This

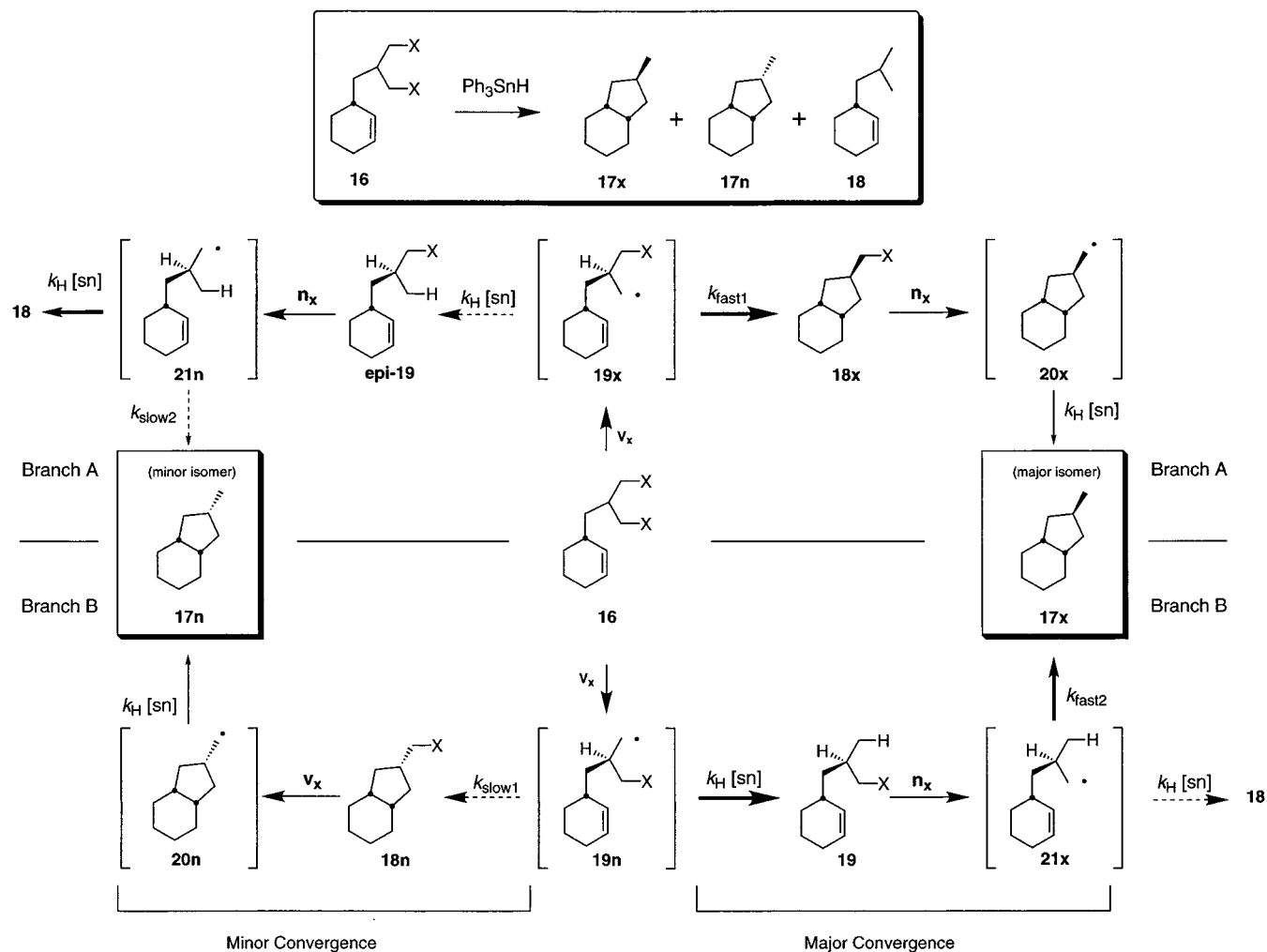

**Figure 9.** Diastereoconvergence by radical cyclization.

eliminates the major convergence branch B and the minor convergence branch A entirely. In this limit, the reaction is a standard stereotopic ligand substitution process in which the ratio of products is determined by the group selectivity in the iodine transfer step. There is no selectivity (by definition), so the ratio of products is 50/50. This shows that the need for simultaneous competing processes is essential; if the two processes are separated in time, the stereoconvergence disappears.

As the tin hydride conversion increases, radical **19n** is reduced competitively with cyclization, and the major convergence branch B is opened to increase the yield of **17x**. Likewise, the minor convergence branch A is opened to bleed away **19x**. But the major convergence has the faster reactions, so the yield of **17x** increases more rapidly than it decreases. Correspondingly, the yield of the minor isomer **17n** decreases, and some doubly reduced product **18** begins to grow in. As the tin hydride concentration continues to increase, the yield of both the major and minor products begins to decrease, but the minor product decreases faster than the major, so the stereoisomeric purity of the major isomer continues to improve even as the excess yield declines. Ultimately, the yields of both exo and endo products approach zero as the tin hydride concentration and *se* approach infinity.

The maximum excess yield observed in this plot is 38% with a corresponding *se* of 48%. Recall that a kinetic resolution with an equivalent selectivity of 5 can offer at most an excess yield of 28% with a *se* of 58% (Figure 1). Although a stereodivergent

(group selective) reaction with the same selectivity can generate as high as a 66% *eY* and *se*, the compound reaction is selective without competition between diastereomeric transition states.

In one view, the compound topography can be used to "correct" an initially unselective step. How efficient this correction is depends on the difference in the rates of the fast and slow cyclization. When these differ only by a factor of 5, the yield of the major isomer can increase from 50% to about 62%. Parts b and c of Figure 10 show the plots if they differ by a factor of 50 or 500. Now the process begins to look more interesting. The yield on one isomer can increase from 50% to 85% with a factor of 50 and to >98% with a factor of 500. We like to view the spread between fast and slow rates as a window. As this window opens wider, there is more room between  $k_{\text{fast}}$  and  $k_{\text{slow}}$  to set the competing process. This allows more material to go through the major convergence and less to go through the minor converge. At some (arbitrary) point above 500 or so, the minor convergence disappears for all practical purposes if the reaction with tin hydride has a suitable rate.

The existence of this window is a direct result of the reaction occurring at the steady state. In the absence of a competing reaction with tin hydride, the relative concentrations of radicals **19x** and **19n** are equal to the inverse of the relative rates of cyclization. Thus, if **19x** cyclizes 500 times faster than **19n**, then **19n** will be present at the steady state at 500 times higher concentration than **19x**. The selective reaction of **19n** with tin hydride is a consequence of this concentration gradient, rather



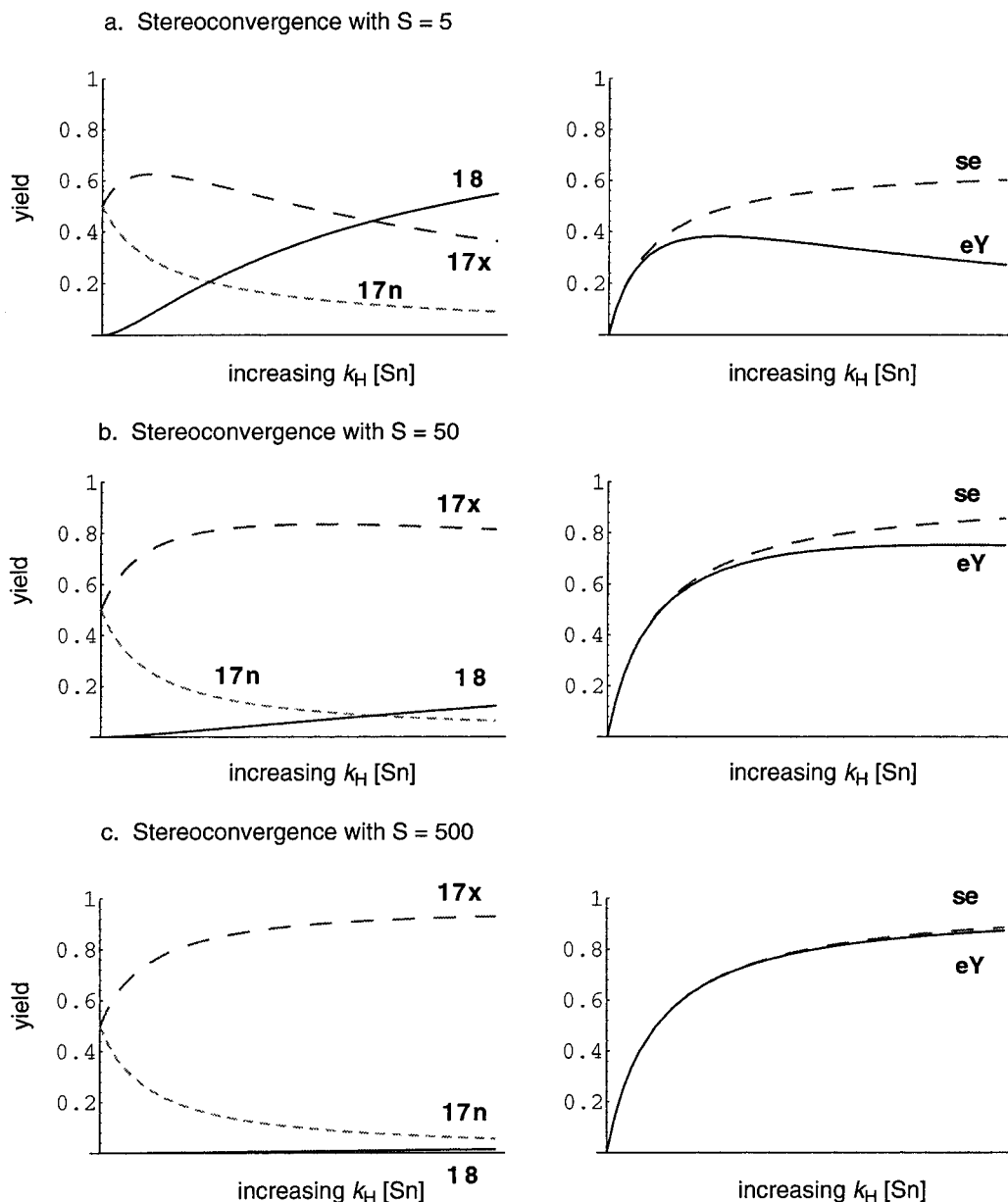

Figure 10. Stereoconvergence with  $S = 5$  (a), 50 (b), and 500 (c).

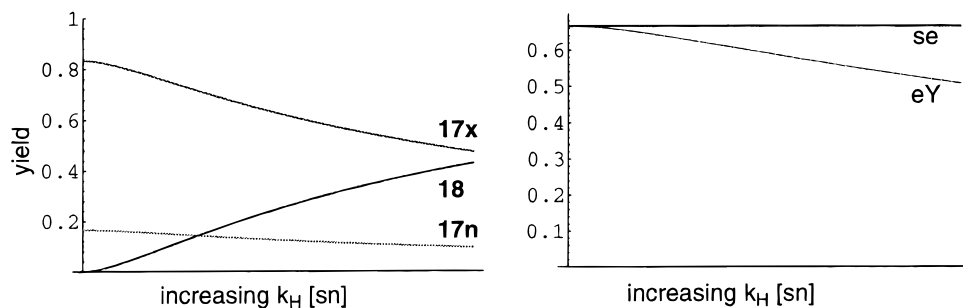
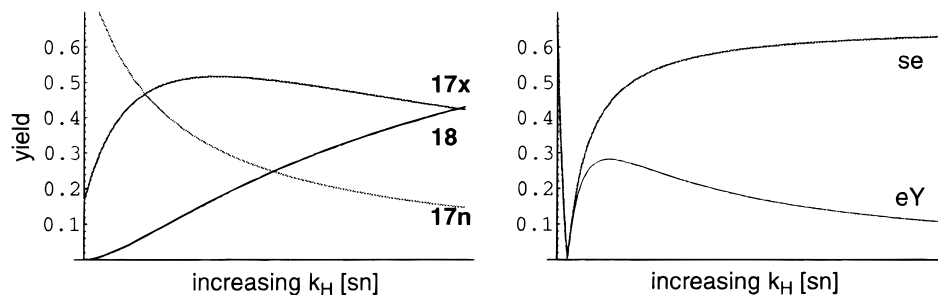

Figure 11. A stereoconvergent system with  $S = 5$  with 5/1 partitioning into branch A.

than an inherent selectivity in rate constants (which are equal by definition).

If the initial stereodivergent event does occur with selectivity, then some interesting behavior is predicted. For example, if the selection favors **19x** with a selectivity of 5 (if  $P_A$  is equal to 5/6 rather than 1/2), then the *se* of the system is found to be independent of  $k_H[\text{Sn}]$  (Figure 11), and the excess yield only decreases over time. As always, at low values of  $k_H[\text{Sn}]$ , the

system reduces to a group selective reaction. In this case, the reaction reaches its maximum *se* and *eY* of 66%—the selectivity of the initial stereodivergent event. We have shifted more of the initial isomer into branch A and less into branch B. As we increase  $k_H[\text{Sn}]$  the opportunity for stereoconvergence occurs, but the new reaction paths are dissimilar. Branch A selectively erodes the material from the type selective event at **19x** that converges to the minor isomer **17n**. Branch B erodes the



**Figure 12.** A stereoconvergent system where  $S = 5$  with 5/1 partitioning into branch B.

material from **19n** converging to the major isomer **17x** to a much lesser extent, but because more of the **19x** isomer is available, the initial stereodivergent event cancels out the enhancement—the result is material is eroded (decreasing the eY) but no change in se is achieved.

That the se is independent of the rate of reaction of radicals with tin hydride arises in this example because the rate ratio and the group selectivity ratio are equal and opposite. The 5/1 concentration gradient in favor of **19n** established by the cyclization occurring at a 5-fold slower rate is exactly canceled by the generation of 5 times more **19x** due to group selection.

This example again provides an illustration that for equal energies of the group selective step and the complex stereoconvergent partitioning, the simple group selective reaction is better. However, if we increase the rate constant ratio of the cyclization above 5, then the compound process enhances both the selectivity and the eY. But when the level of group selection exceeds the level of selection in the second stage, then the process starts to reverse due to enhancement of the minor product. Consequently, there is first erosion and then reversal (in other words, the minor product becomes favored) of the se and eY.

For example, if the initial stereodivergence favors the isomer **19n** with the same selectivity of 5 (if  $P_A$  is  $1/6$ ), then we see a very different component profile (Figure 12). At low values of  $k_H$ [Sn], elementary group selection favors the isomer **17n**. As the  $k_H$ [Sn] factor is increased, both **19x** and **19n** converge, but in this case the type selective enhancement favors the material that was produced in excess from the initial selective event. As a result production of isomer **17x** quickly overtakes that of **17n**—reversing the selectivity of the process. With low tin concentration, isomer **17n** is favored with a se and eY of 66%, at higher tin concentrations the *opposite* isomer **17x** is favored with a se 43% and an eY of 28%, and at still higher concentrations that opposite isomer is favored by a se of 66% (however, the eY drops to 12%). Much more dramatic reversals can be simulated by using larger differences in rate constants.

The process represented by the hypothetical example in Figure 10 is only one of a number of conceivable variants that we envision for the process. It is a diastereoselective variant in which the stereoselective process is intermolecular and the nonstereoselective one is bimolecular. This is the only variant to date that has any experimental support. In Figure 13, we illustrate this process along with five other variants, all in the context of competing radical additions and reductions.<sup>18</sup> We stress that none of these examples are necessarily predicted to be stereoselective, or for that matter even to work. They simply embody the features of the kinds of variants that we envision and are perhaps more easy to grasp than generic examples. We further stress that the underlying principles of these examples

have nothing to do with radical chemistry. The kinetic models all contain generalized reagent concentrations and rate constants. The models are applicable to any type of competing chemical processes meeting the competition kinetic requirements.

The examples in Figure 13 systematically vary which process is selective, the addition or the reduction. Each process can also be first order or second order. From the kinetic standpoint, the equations fall into three pairs because the choice of which process is stereoselective (hydrogen transfer or reduction) has identical effects on different pairs of components of the reaction. Systems in which both reactions are intramolecular are omitted because they are of no special interest; they are standard intramolecular competitions whose rate ratios are constant. The sample reaction in Figure 13, entry 1, is an example of a diastereotopic group selective process, as its partner, entry 5, where the intra- and intermolecular steps are reversed. The other systems are all enantiotopic group selective processes, and the products of these processes can be enantiomers or diastereomers depending on the design.

Reaction 4 provides a simple example of a (potential) catalytic enantioselective process. If a chiral metal hydride ( $M^*H$ ) were available that would differentiate between the enantiomeric radicals derived from a dihalide, then an enantioselective cyclization could be conducted. Recycling of the chiral tin halide product to a tin hydride is well precedented.<sup>19</sup> Reactions of chiral tin hydrides are in their infancy,<sup>20</sup> and this type of reaction does not yet appear practical. However, the concept stands, and the illustrated radical reactions can be replaced with any type of reaction.

Reaction 3 also demonstrates some unique properties. This incarnation involves the reaction of an achiral substrate **22** with chiral radical acceptor **23** in the presence of a chiral reducing agent to achieve diastereoconvergence (Figure 14). Substituting the appropriate rate constants and steady-state concentrations of the alkene trap and hydrogen donor into the general stereoconvergent model eqs 3–6 and simplifying produces a rather complex set of equations shown in the Supporting Information. If we make the assumption that the selectivity in the rate of addition of alkene to each of the bracketed intermediates is the same in this system, the product distribution model for example 3 simplifies considerably. This assumption says that the rate of addition of the radical to the alkene depends only on the absolute configuration of the radical, not on the nature of the remote substituent ( $CH_3$ - or  $XCH_2$ -).

Elimination of the initial partitioning factor  $P_A$  produces the simplified product distribution functions 10–13. The consequence of this elimination is that selective stereoconvergence in this system—unlike reaction 2—occurs with no dependence on the initial partitioning by abstraction of X under any conditions! This invariance of the yields and stereomeric excess

(18) For intramolecular reactions of silicon hydrides, see: Curran, D. P.; Xu, J. Y.; Lazzarini, E. *J. Chem. Soc., Perkin Trans. 1* **1995**, 3049.

(19) Stork, G.; Sher, P. M. *J. Am. Chem. Soc.* **1986**, *108*, 303.

(20) Nanni, D.; Curran, D. P. *Tetrahedron-Asymmetry* **1996**, *7*, 2417.

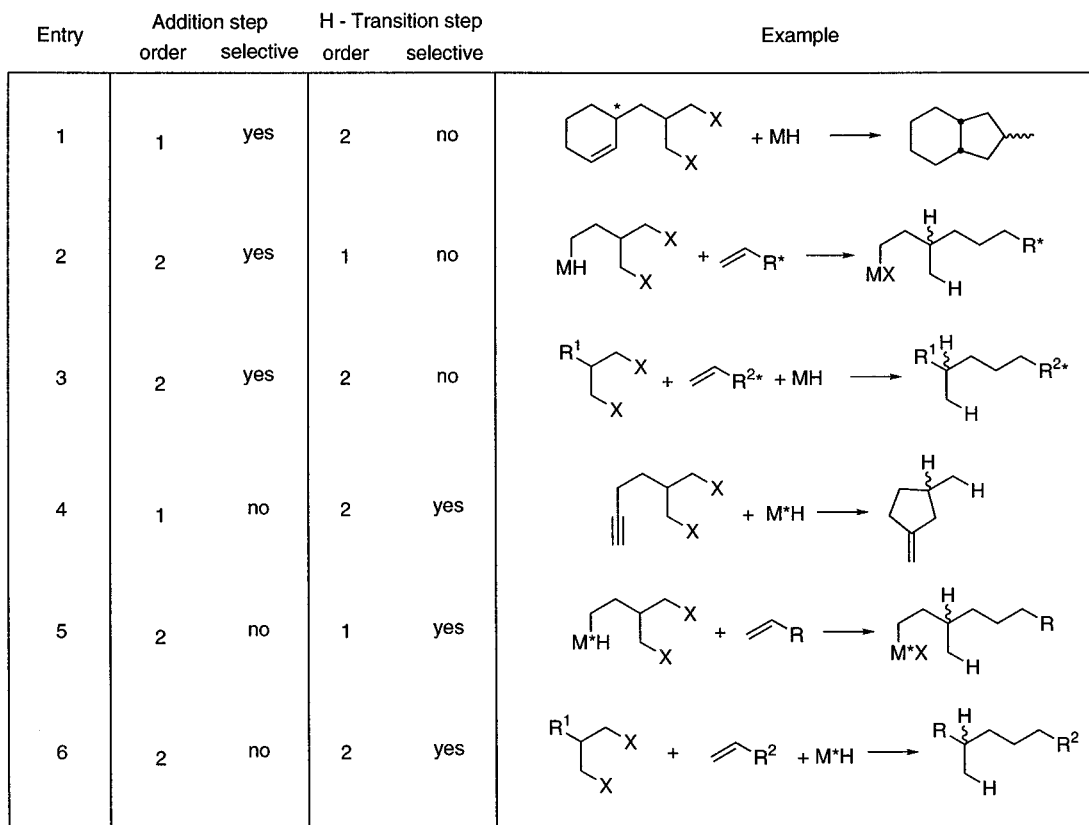

Figure 13. Hypothetical implementations of compound stereoselectivity in group selective radical reactions.

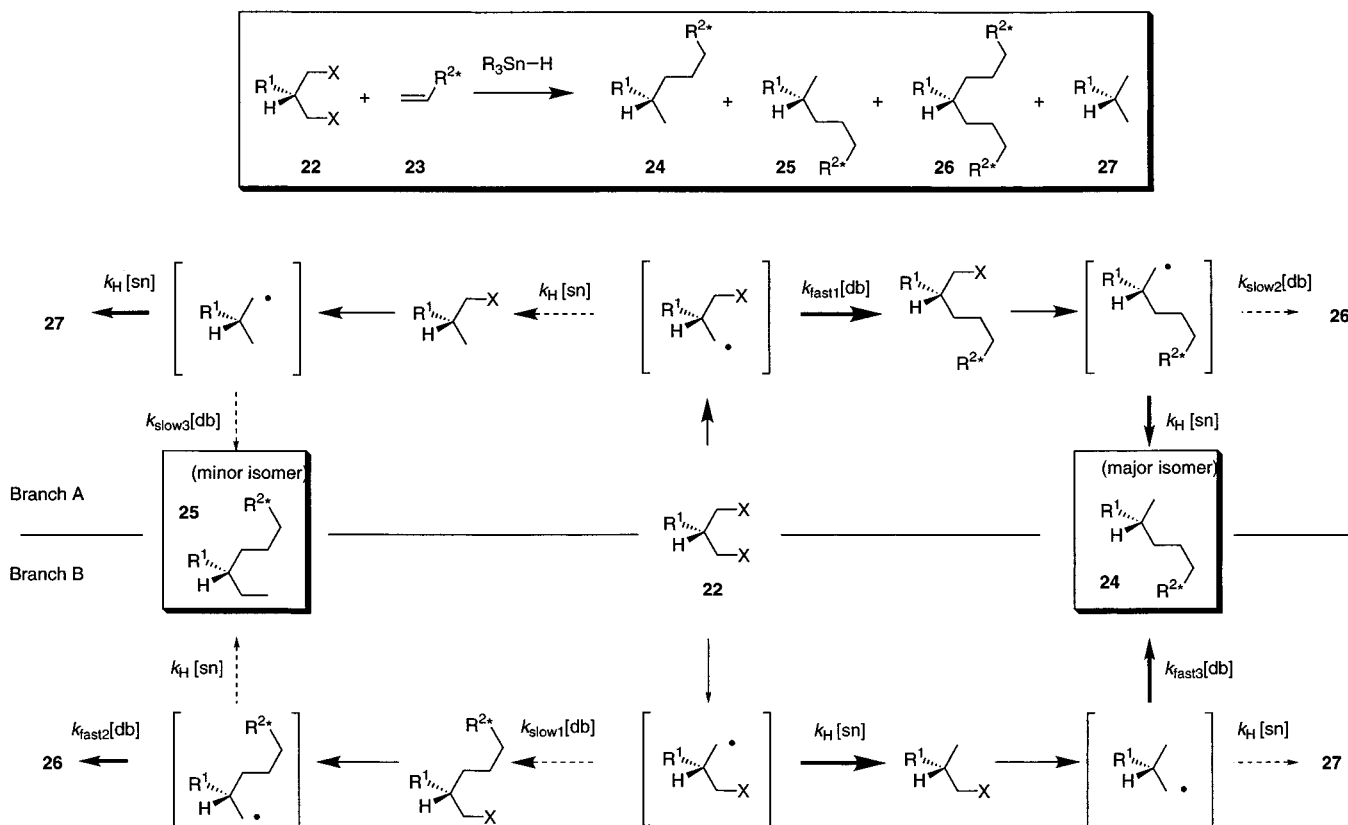
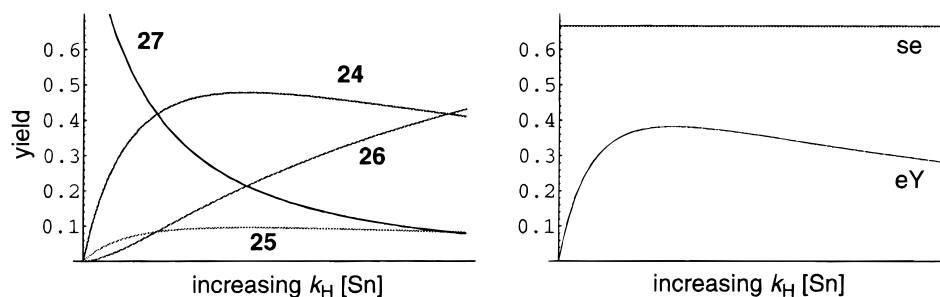

Figure 14. Stereoconvergence with competing bimolecular reactions.

to the initial partitioning can be understood by recognizing a symmetry in the system. Two enhancements occur in each branch—one eroding the undesired material and the other favoring production of the desired isomer. If the initial substrate

**22** partitions 50% into branch A and 50% into branch B, then the symmetry dictates that 50% of the major product **24** comes from branch A and 50% from branch B. Changing the partitioning to, say, 90% leaves the yield of **24** unchanged, only



**Figure 15.** Yield and selectivity levels in Figure 17 with  $S = 5$ .

now 90% of **24** comes from branch A and 10% from branch B.

$$[\mathbf{26}]_{\%} = \frac{k_{\text{slow}}[\text{db}]}{k_{\text{slow}}[\text{db}] + k_{\text{H}}[\text{Sn}]} \cdot \frac{k_{\text{fast}}[\text{db}]}{k_{\text{fast}}[\text{db}] + k_{\text{H}}[\text{Sn}]} \quad (10)$$

$$[\mathbf{24}]_{\%} = \frac{k_{\text{H}}[\text{Sn}]}{k_{\text{slow}}[\text{db}] + k_{\text{H}}[\text{Sn}]} \cdot \frac{k_{\text{fast}}[\text{db}]}{k_{\text{fast}}[\text{db}] + k_{\text{H}}[\text{Sn}]} \quad (11)$$

$$[\mathbf{27}]_{\%} = \frac{k_{\text{H}}[\text{Sn}]}{k_{\text{slow}}[\text{db}] + k_{\text{H}}[\text{Sn}]} \cdot \frac{k_{\text{H}}[\text{Sn}]}{k_{\text{fast}}[\text{db}] + k_{\text{H}}[\text{Sn}]} \quad (12)$$

$$[\mathbf{25}]_{\%} = \frac{k_{\text{slow}}[\text{db}]}{k_{\text{slow}}[\text{db}] + k_{\text{H}}[\text{Sn}]} \cdot \frac{k_{\text{H}}[\text{Sn}]}{k_{\text{fast}}[\text{db}] + k_{\text{H}}[\text{Sn}]} \quad (13)$$

These functions are used to plot in Figure 15 the component profile of the system in Figure 13; as usual, the partitioning is 50/50 and the rate constant ratio is 5/1. The stereomeric excess of 66% is invariant with respect to the  $k_{\text{H}}[\text{Sn}]$  value; however, this variable can be used to optimize the eY to a maximum of 38% (for the selectivity of 5). This system is perhaps the best demonstration of the fact that the stereoconvergent system results in significant se and eY without any dependence on selectivity in the one event in the system where stereomeric transition states directly compete.

Example 6 is complement to example 3, and again the use of a catalytic amount of a chiral tin hydride allows in principle an enantioselective radical addition to an achiral alkene!

## Conclusions

From the basic principles of stereochemistry and by using a standard kinetic analysis, we have formulated a new class of "complex stereoselective" reactions. According to our analysis, if the correct kinetic conditions are met, net group selective processes can be observed in reactions in which the group selective step occurs randomly or even in favor of the (ultimate) minor product. While the standard elementary reactions of group selection and kinetic resolution are components of these processes, the ratios of the stereoisomeric products do not depend directly on these processes, but are instead the result of convergent reaction topography that requires a second component to effect a chemoselective step.

These complex stereoselective reactions are fascinating because the number of possibilities for reaction profiles is virtually limitless. We have illustrated here only a few possibilities of some reaction types, and indeed even among these, we have made assumptions that simplified the analysis (and hence the appearance of the product curves). For example, we have assumed that the ratios in the chemoselective partitioning events depend only on the configurations of the radicals. But this assumption need not be true since the reactive radicals

are not the same. If two events are selective rather than one, the process acquires a parallel kinetic resolution component.<sup>12f</sup>

Furthermore, the analysis can be immediately expanded beyond group selective reactions. For example, the products from the initial group selective reaction in all this work are enantiomers (or diastereomers). It follows then that any method of producing and reacting enantiomers (or diastereomers) at the steady state is subject to the same effects. To give a simple example, it is possible to envision a process where prochiral ketone is reduced unselectively to a racemic mixture of alcohols. As formed, the enantiomeric alcohols could be rapidly consumed by two competing chiral and achiral reagents (or catalysts) to give structurally different products (assuming that the rates of all the competing processes are in order). The result of an idealized process would be production of structurally different derivatives of each enantiomer of the alcohol. This steady-state process is fundamentally different from a standard kinetic resolution of an alcohol, and it therefore cannot be duplicated by starting with a racemic mixture of alcohols. And the orchestration of events provided by a complex process provides some better (and even more difficult to achieve) scenarios. For example, if one of the above two competing processes were an inversion, then the same products would form from both pathways!

How could such a diverse and interesting branch of stereo-selective reaction kinetics have escaped notice for so long? The answer may lie in the limitations of these types of processes. First of all, to use complex processes in a stereoconvergence mode requires group selection, which is much less common than face selection. Nonetheless, group selection is often used in synthesis and a crucial event in such things as terminus differentiation in two directional chain synthesis.<sup>21</sup>

Second, given equal energetics, a normal group selective process will give at least equal and usually better eY than a stereoconvergent process. This is because of the kinetic resolution features of the complex stereoconvergence.

Third, it is important that the reaction passes through transient intermediates. The process is not conceivable when initial reaction of the stereotopic groups occurs in one step to directly add the final group; this is a standard group selective process. Although there have to be intermediates, they do not necessarily have to be transient. But some reflection suggests that the generation of stable intermediates is not very practical. The whole transformation would then have to occur in time-resolved stages, one after the other, and the concentration gradient provided by the steady state would be lost. With transient intermediates, the whole process can occur concurrently, and as such can in principle be rendered catalytic.

Finally, the need for competing reactions is inescapable, and the rate of the competition is crucial. Organic reactions vary

(21) (a) Poss, C. S.; Schreiber, S. L. *Acc. Chem. Res.* **1994**, *27*, 9. (b) S. R. Magnusson, *Tetrahedron* **1995**, *51*, 2167.

over a huge range of rates, but the interesting stereoconvergent phenomena are only exhibited in the competition range where (in the simple model) the rate of the nonselective reaction is between the rates of the two selective ones. In this sense, while radical reactions are by no means required to execute any of the transformations, they do provide an ideal discovery ground because they naturally occur at the steady state and because there is now a huge body of data, both qualitative and quantitative, that can be used to evaluate competing radical reactions.

Limitations notwithstanding, the theories that we have put forth propose clear and present challenges to the field of experimental stereochemistry. Only one of the classes of processes have been verified experimentally to date, and even in that class only a simplified model has been used.<sup>5</sup> Can examples of the other classes be found? Especially challenging are catalytic enantioselective possibilities. If such reactions could be discovered, they could have clear preparative value. While radical chemistry is one fertile area for discovery of

stereoconvergent reactions, it is not the only one. Like radical chemistry, organometallic chemistry involves transient intermediates that can be directed to partition in different ways. And the base of asymmetric reactions in general (especially in asymmetric catalysis) is much broader in organometallic chemistry than it is in radical chemistry. So this field would appear to provide a good hunting ground for stereoconvergent processes.

**Acknowledgment.** We thank the National Science Foundation for funding this work. We are also grateful to Professors C. Walling and C. Wilcox for helpful discussions about the mathematical analysis.

**Supporting Information Available:** Complete derivations of generalized kinetic models for all the classes of reactions (28 pages). See any current masthead page for ordering and Internet access instructions.

JA9724093